



RADOM™

Reimagine Plasma

MINING AND MINERAL ANALYSIS

MICAP™-OES 1000

- Highly efficient nitrogen plasma
- Simultaneous measurement
- Low running cost
- Smallest footprint

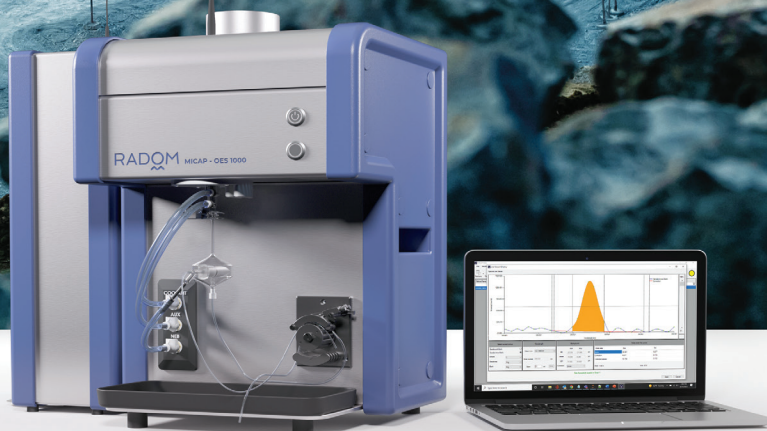

Authors:

Eric Moen, Lead Application Chemist

Jake Biesterveld, ICP-OES Chemist

Christine Rivera, Director of Product Management/Chemist

Mining exploration and production rely on atomic spectroscopy instrumentation to map the location and determine the elements interest. The core samples in exploration typically are collected, milled for homogeneity, and sent to a laboratory for analysis. The delay from sampling to analysis is a bottleneck. MICAP-OES 1000 with Cerawave™ technology **can be installed at the exploration location and can significantly shorten the operations decision time.**

Current, traditional laboratory techniques used to analyze metals in geological samples are atomic absorption and inductively coupled argon plasma optical emissions spectroscopy (ICP-OES). The former uses combustible gases and has limited range capability while the latter uses argon gas and typically requires a chiller for cooling. Both techniques are not conducive to remote mobile, local, or remote laboratory testing labs.

Radom Corporation developed the solution for instrumentation on location with Microwave Indicatively Coupled Atmospheric Plasma - Optical Emission Spectrometer with 1000 W power (MICAP-OES 1000). This innovated nitrogen-based plasma atomic spectroscopy instrument replaces the traditional argon generated plasma technology. MICAP-OES 1000 uses **highly efficient** Cerawave technology that replaces the electric water-cooled coil found in commercially available ICP-OES instruments today and **does not require water cooling**. [MICAP-OES 1000 can operate on 110V or 220V, drawing power from regular outlets]. Industrial grade nitrogen (99.98%) is **much cheaper than argon**. Nitrogen can be **produced locally with a nitrogen generator** which eliminates the problem of ongoing sourcing of gases. It **eliminates the need for combustible gases** in remote locations.

MICAP-1000 **has the smallest footprint** of any commercially available optical emission spectrometer with an **easy-to-use** RIS (Radom Intuitive Software) application software. The power of Cerawave technology coupled with a **high-resolution** sCMOS provides **simultaneous measurement of elements** in the prepared sample. The ability to screen core samples on location means results can be determined more quickly. An added benefit is capability to collect more samples in an area to create a comprehensive map of the potential yield.

MICAP-OES 1000 is a compact easy-to-use and install instrument.

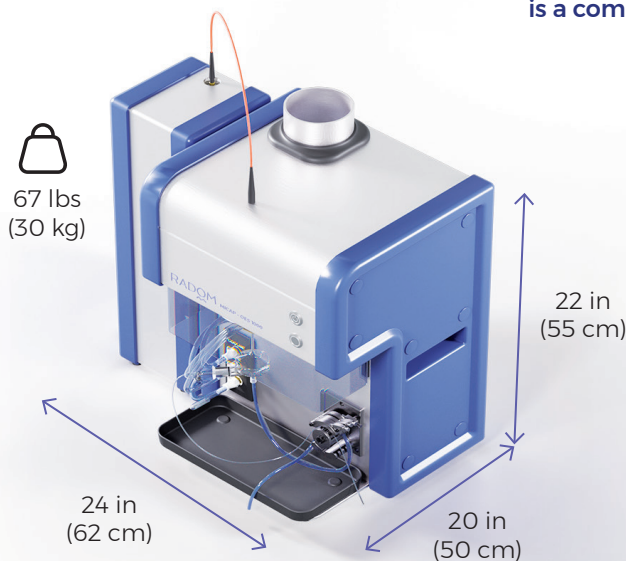

Figure 1: MICAP-OES 1000 Dimensions. Small, light-weight design made possible by Cerawave

MICAP-OES 1000 was utilized to analyze digested OREAS CRMs with certified values for preparation in aqua regia. Aqua regia is a partial digestion using nitric and hydrochloric acid at a 1:3 ratio (1).

This application brief will describe the standard/sample preparation, MICAP-OES 1000 instrument technology, hardware description, method parameters and result summary. The primary element for determination was gold in the aqua regia leachates. Since MICAP-OES 1000 has simultaneous analysis capabilities, the analysis extended to other elements in the certified reference materials.

Table 1. Sample Introduction Area (SIA)

Autosampler	Teledyne Cetac Technologies ASX-560
Sample Tubing	Black/black PVC 0.76 mm ID
Drain Tubing	Yellow/blue PVC 1.52 mm ID
Nebulizer	Low-flow quartz nebulizer 1.0 mL/min
Spray chamber	Single pass cyclonic
Torch	20 mm quartz torch with 1.5 mm injector

Sample Introduction Assembly (SIA) is installed simply by pressing the torch guide clamp handles together, guiding the torch into the orifice until the pegs stop the torch movement, release the clamp. The plasma position is permanently set with no plasma viewing alignment necessary. Figure 1 illustrates the torch base with position pegs, torch holder orifice with holder handle and torch perfectly fitted into position.

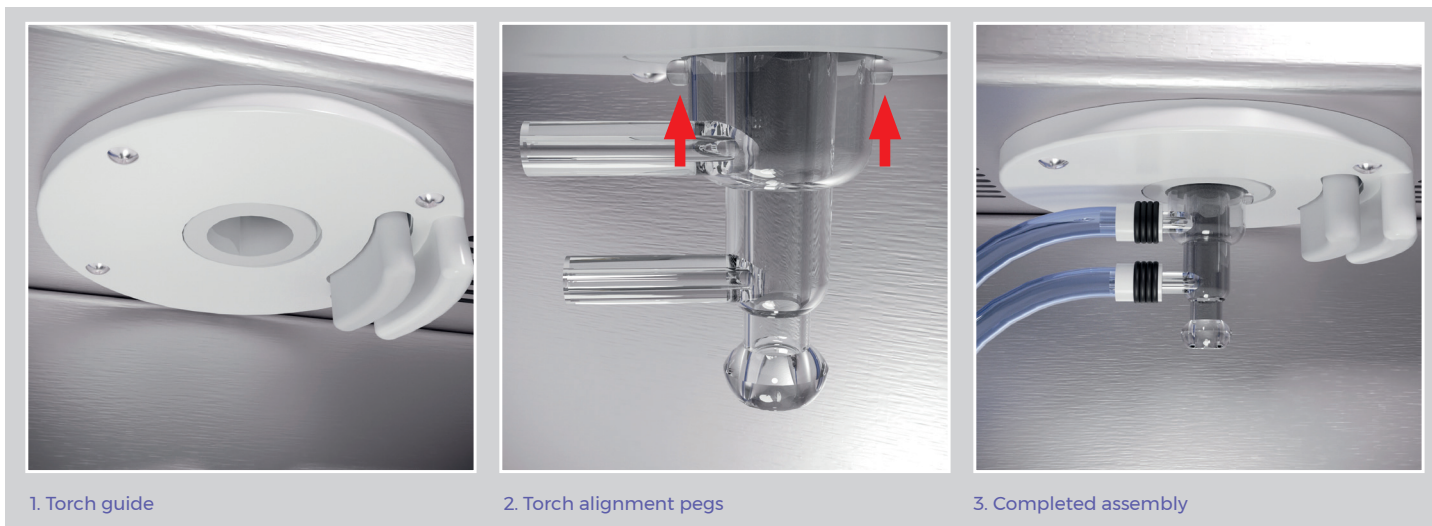

Figure 2: Torch holder assembly

The spray chamber/nebulizer assembly is clipped onto the ball joint socket to complete the SIA. The pump tubes are installed and easily connected to the SIA.

Test Sample Preparation

For this study, multiple CRMs were purchased from OREAS. These CRMs are developed exclusively for mining, exploration and analytical industries (2). Table 2 presents the CRM IDS and a description of the matrix.

Table 2. OREAS CRM ID and Matrix Description

OREAS CRM ID	matrix description
238	3.03 g/t Au (metasediment) OREAS 238 - 60g
242	8.67 g/t Au (greenstone) OREAS 242 - 1kg
255B	4.16 g/t Au (weathered greenstone) OREAS 255b - 60g
256B	7.84 g/t Au (weathered greenstone) OREAS 256b - 500g
257B	14.22 g/t Au, 2.36g/t Ag, 5.14% Al (weathered greenstone) OREAS 257b - 500g

To prepare the CRM samples, ~2 gms of each CRM was weighed into a 50-mL graduated DigiTube (SCP Science). To each weighed sample, 2mL nitric acid (HNO₃), 6mL hydrochloric acid (HCl) and 20mL TypeII water was added. A single-use polymeric watch-glass was placed on each tube. A digestion blank prepared as the samples was included with each preparation set.

The test solutions were refluxed for 2 hours at 95°C utilizing the DigiPREP Jr (50ml). The test samples were allowed to cool to ambient temperature, diluted to 50-mL with water and filtered with 1.0 µm hydrophilic teflon®.

Calibration Standard Preparation

Working standard solutions were prepared in 50-mL DigiTubes. The concentration range was 0.025 ppm to 20 ppm in 12% HCl/4% HNO₃ diluent. The calibration standard concentrations and parameters are summarized in Table 3. MICAP-OES 1000 method parameters are summarized in Table 4.

Table 3. Standard solution concentration and calibration parameters summary

Calibration Parameter	Input
Standard 1	0
Standard 2	0.025
Standard 3	0.10
Standard 4	0.25
Standard 5	0.50
Standard 6	1.00
Standard 7	5.00
Standard 8	10.00
Standard 9	20.00
Through Origin	No
Weighted	No
Fitting Method	Linear
Correlation Coefficient Limit	0.995
Individual Standard Max Error (%)	20

Table 4. Method Instrument and sampling parameters summary

Method Instrument and Sampling Parameters	Input
Scans per replicate: 10	10
Replicates per sample: 3	3
Camera exposure: [ms]	10,000
Coolant flow: [L/min]	14.00
Auxiliary flow: [L/min]	0.20
Nebulizer flow: [L/min]	1.00
Microwave power: [W]	1000
Pump rate: [rev/min]	25
Pump speed during rinse: [rev/min]	100
Pump speed during uptake: [rev/min]	100
Sample update delay time: [s]	20

Figure 3 presents typical calibration curves for Ag, Au, Pd and Pt using linear regression with calculated regressions and software calculated LOD (limit of detection) for each wavelength.

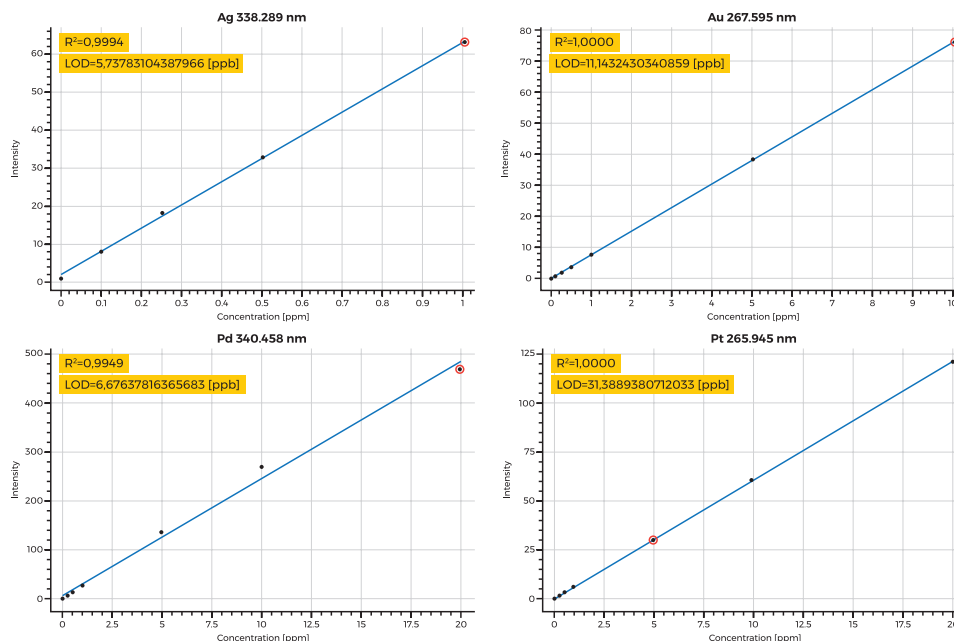

Figure 3. Example calibration curves for Ag, Au, Pd and Pt

Results and Discussion

The CRM ID listed in the Table 1 summary provides certified results for gold based on statistical results submitted from participating laboratories. The certificate provides gold certification with preparation of ore by Pb (lead) fire assay, 4-acid digestion, aqua regia and cyanide leach. The study performed with MICAP-OES 1000 was aqua regia preparation only. According to the certificates, the aqua regia digestion participants use ICP-OES, ICP-MS and AAS to report the gold values in the ore.

The CRMs were prepared in duplicate and no additional dilution was required from the digested preparation of 2gms to 50mL.

Table 5. OREAS CRM Results for Gold in Aqua Regia Digestions

Analyte	Wavelength	CRM ID	Certified Value	Preparation 1	Preparation 2	Dilution	Recovery1	Recovery2
Au, ppm	267.595	238	2.95	2.99	2.84	1x	101%	96%
		242	8.33	6.95	7.28	1x	83%	87%
		255b	4.08	3.82	3.77	1x	94%	92%
		256b	7.58	7.61	7.13	1x	100%	94%
		257b	14.17	14.55	15.42	1x	103%	109%

MICAP-OES 1000 utilizes a sCCD camera with the ability to capture the spectrum between 194nm and 625nm. The following tables represent additional elements determined in the digested CRM samples. The Pd and Pt certified values for some of the CRMs were below the method detection limits for the MICAP-OES 1000.

The Al and mineral concentrations for the OREAS CRM standards are reported in WT%. In order to determine the concentration of these elements, additional dilutions were prepared such that the working concentration was below the 20 ppm high standard concentration.

The following tables summarize the results for the OREAS CRMs for the additional elements added to the instrument method.

Table 6. Oreas CRM 238 Result Summary

CRM ID 238	Wavelength	Certified Value	Preparation 1	Preparation 2	Dilution	%REC 1	%REC 2
Ag, ppm	338.289	0.22	<1	<1	1x	*	*
Al, wt.%	308.215	2.39	2.48	2.43	100x	104%	102%
As, ppm	228.812	628	628	728	2x	100%	116%
Ba, ppm	413.065	99	104	99	1x	105%	100%
Ca, wt.%	317.933	0.23	0.25	0.23	20x	107%	100%
Ce, ppm	446.021	55	50.6	54.9	1x	92%	100%
Co, ppm	228.616	12.2	15.4	16.3	1x	126%	133%
Cr, ppm	283.563	96	109	113	1x	114%	117%
Cu, ppm	327.396	28.6	37.6	38.1	1x	131%	133%
Fe, wt.%	238.204	3.38	3.45	3.38	100x	102%	100%
La, ppm	432.521	27.7	30.0	26.3	1x	108%	95%
Mg, wt.%	279.553	1.25	1.33	1.32	200x	106%	106%
Mn, wt.%	259.372	0.022	0.0240	0.0218	20x	109%	99%
Na, wt.%	589.592	0.07	0.081	0.080	100x	116%	114%
Ni, ppm	361.939	55	61	63	1x	111%	115%
Pr, ppm	525.973	7.15	6.78	5.82	1x	95%	81%
Sb, ppm	217.581	461	523	573	1x	114%	124%
Th, ppm	439.111	12.3	13.7	15.7	1x	111%	128%
Ti, wt.%	323.451	0.13	0.15	0.15	50x	113%	113%
V, ppm	289.332	64	60.3	64.2	1x	94%	100%
Y, ppm	371.029	8.96	8.54	8.37	1x	95%	93%
Zn, ppm	202.548	77	76.2	76.4	1x	99%	99%

* Ag, ppm - certified value in the prepared test solution was below detectable limit.

Table 7. OREAS CRM 242 Result Summary

CRM ID, 242	Wavelength	Certified Value	Preparation 1	Preparation 2	Dilution	%REC 1	%REC 2
Ag, ppm	338.289	2.05	2.04	2.10	1x	100%	103%
Al, wt.%	308.215	3.2	3.00	3.00	200x	94%	94%
As, ppm	228.812	66	73	71	1x	110%	108%
Ba, ppm	413.065	35.1	41.2	36.2	1x	117%	103%
Ca, wt.%	317.933	2.66	2.77	2.79	200x	104%	105%
Ce, ppm	430.672	10.9	10.4	9.8	1x	96%	90%
Co, ppm	228.616	28.9	31.7	33.3	1x	110%	115%
Cr, ppm	425.435	26.1	17.6	17.5	1x	67%	67%
Cu, ppm	327.396	171	210	225	1x	123%	131%
Fe, wt.%	238.204	5.54	5.50	5.54	200x	99%	100%
Mg, wt.%	279.553	1.59	1.60	1.62	200x	101%	102%
Na, wt.%	589.592	0.257	0.250	0.252	200x	97%	98%
Nd, ppm	401.225	6.39	7.16	7.18	1x	112%	112%
Ni, ppm	361.939	48.9	37.4	44.7	1x	76%	92%
Pr, ppm	525.973	1.41	1.81	1.90	1x	128%	134%
Sm, ppm	442.053	1.64	1.01	1.18	1x	61%	72%
Ti, wt.%	323.451	0.33	0.40	0.38	50x	120%	115%
V, ppm	289.332	142	144	143	1x	101%	101%
Y, ppm	437.493	12.1	12.4	12.4	1x	102%	103%

Table 8. OREAS CRM 255b Result Summary

CRM ID 255b	Wavelength	Certified Value	Preparation 1	Preparation 2	Dilution	%REC	%REC2
Ag, ppm	338.289	0.793	<1	<1	1x	*	*
Al, wt.%	308.215	1.49	1.50	1.48	50x	101%	99%
As, ppm	228.812	409	445	446	1X	109%	109%
Ba, ppm	413.065	58	69	69	1x	119%	119%
Ca, wt.%	317.933	0.358	0.372	0.375	50x	104%	105%
Ce, ppm	413.830	53	55.7	55.5	1x	105%	105%
Co, ppm	228.616	15.7	18	17	1x	116%	107%
Cr, ppm	283.563	110	125	125	1x	114%	114%
Cu, ppm	327.396	65	75	74	1x	116%	114%
Fe, wt.%	238.204	3.76	3.44	3.42	200x	92%	91%
La, ppm	432.521	27.9	29	29	1x	105%	105%
Mg, wt.%	279.553	0.825	0.847	0.858	200x	101%	99%
Na, wt.%	589.592	0.192	0.185	0.186	200x	96%	97%
Nd, ppm	401.225	24.3	26.3	26.4	1x	108%	108%
Ni, ppm	361.939	76	78	77	1x	103%	101%
Pr, ppm	525.973	6.2	6.6	6.6	1x	106%	107%
Sm, ppm	442.434	4.59	5.21	5.12	1x	114%	112%
Th, ppm	491.982	7.9	8.9	9.1	1x	113%	115%
Ti, wt.%	323.451	0.077	0.081	0.081	50x	105%	106%
V, ppm	289.332	48.3	49.32	49.6	1x	102%	103%
W, ppm	429.461	28.7	25.4	25.4	1x	88%	89%
Y, ppm	360.073	9.31	8.53	8.79	1x	95%	94%
Zn, ppm	202.548	65	66	67	1x	102%	103%

* Ag, ppm - certified value in the prepared test solution was below detectable limit.

Table 9. OREAS CRM 256b Result Summary

CRM ID 256b	Wavelength	Certified Value	Preparation 1	Preparation 2	Dilution	%REC 1	%REC 2
Ag, ppm	338.289	1.33	<1	<1	1x	*	*
Al, wt.%	308.215	1.74	1.70	1.64	50x	98%	95%
As, ppm	228.812	267	305	295	1X	114%	110%
Ba, ppm	413.065	62	67	72	1x	108%	116%
Ca, wt.%	317.933	0.458	0.446	0.420	20x	97%	92%
Ce, ppm	446.021	36.6	38.8	38.3	1x	106%	105%
Co, ppm	228.616	19.8	21.5	19.6	1x	108%	99%
Cr, ppm	283.563	175	194	188	1x	111%	107%
Cu, ppm	327.396	91	105	102	1x	116%	112%
Fe, wt.%	238.204	3.45	3.27	3.28	100x	95%	95%
Mg, wt.%	280.27	1.25	1.29	1.26	50x	104%	101%
Mn, wt.%	259.372	0.027	0.027	0.026	20x	102%	95%
Na, wt.%	589.592	0.138	0.136	0.142	100x	98%	103%
Nd, ppm	430.357	16.6	17.5	17.1	1x	106%	103%
Ni, ppm	361.939	90	97	93	1x	108%	103%
Pr, ppm	525.973	3.84	4.5	4.3	1x	118%	112%
Sm, ppm	442.434	3.21	3.63	3.81	1x	113%	119%
Th, ppm	491.982	5.43	5.5	4.69	1x	101%	86%
Ti, wt.%	323.451	0.062	0.068	0.066	50x	109%	106%
V, ppm	289.332	57	59.4	58.3	1x	104%	102%
W, ppm	429.461	17.8	16.8	17.0	1x	94%	95%
Y, ppm	360.073	7.76	7.50	7.18	1x	97%	93%
Zn, ppm	202.548	59	63	61	1x	107%	104%

* Ag, ppm - certified value in the prepared test solution was below detectable limit.

A series of QC solutions were prepared in aqua regia and analyzed at the end of the analysis session. These QC solutions were prepared with concentrations of 5.0 ppm, 1.0 ppm, 0.50 ppm, 0.25 ppm, 0.10 ppm and 0.025 ppm. Figure 4 graphically displays the recovery of the solutions. It should be noted that some wavelengths selected did not have significant sensitivity to determine the 0.025 ppm QC solution.

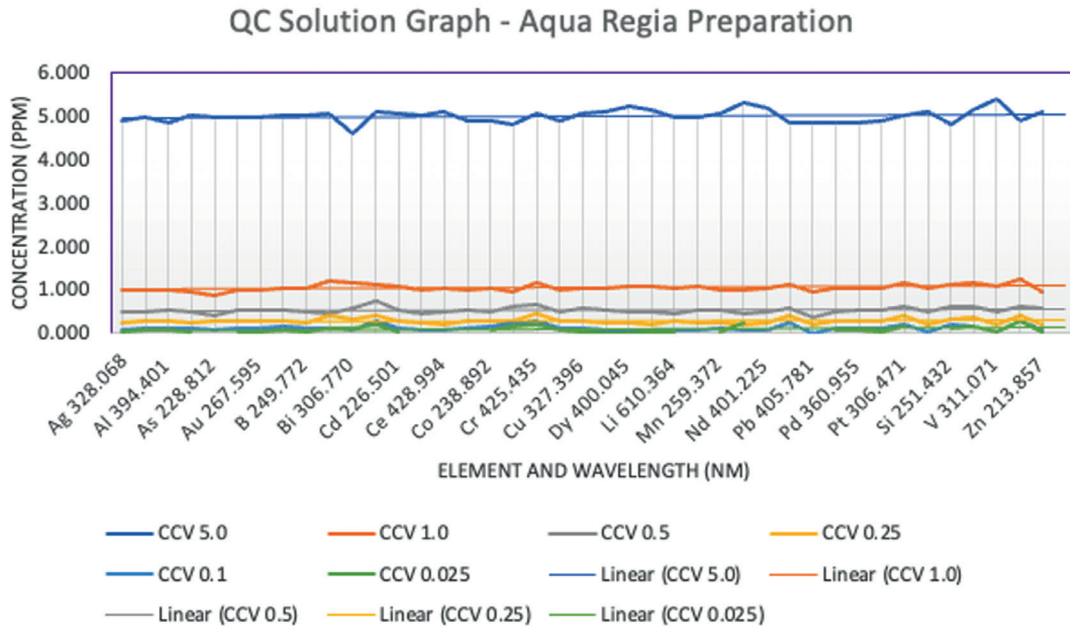

Figure 4. QC Standard Recovery

MICAP-OES 1000 was utilized to determine elements in OREAS certified materials. The gold results were in alignment with the expected CRM concentrations. The method development for additional elements is underway.

References:

- (1) www.angloamericanplatinum.com/-/media/Files/A/Anglo-American-Platinum
- (2) <https://www.scienceabc.com/pure-sciences/aqua-regia-formula-recipe-structure-dissolve-gold-platinum.html>

www.radomcorp.com

Radom Corporation
 N27W23676 Paul Rd.
 Pewaukee, WI 53072 USA

Copyright © 2022 Radom Corp.

This information is subject to change without notice.

email: inquiries@radomcorp.com
 tel: 877-977-2366

Scan the code to access our website for additional information and our resources



MICAP-011-22-Rev.B