

M-110EH-30 Electric-Hydraulic Laboratory Microfluidizer Processor for Continuous High Shear Fluid Processing

M-110EH-30 Microfluidizer® Processor, Standard and Explosion-proof

Recommended for:

- Particle Size Reduction for Submicron and Nano-sized Particles
- Deagglomeration
- Cell Disruption
- Immiscible Liquid Emulsions
- Solid-in-Liquid Suspensions
- Liposomes

The M-110EH-30 has been designed to reliably achieve continuous operating pressures to 30,000 psi. The processor maximizes the energy-per-unit fluid volume, resulting in uniform submicron particle and droplet sizes.

Utilizing Microfluidics' fixed geometry diamond interaction chamber technology, and a ceramic (Zirconia) plunger, the M-110EH-30 is capable of processing a wide variety of fluids such as simple oil-in-water emulsions, solids-in-liquid suspensions, and cell disruptions, including the most difficult yeasts and plant cells, in 1-2 passes. What's more, the process is repeatable and is guaranteed to scaleup to pilot and/or production volumes.



The M-110EH-30 Microfluidizer processor combines superior, scalable results with easy handling and clean-in-place

- Process pressure to 30,000 psi (2,070 bar)
- Flow rates to 330 mL/min at 30,000 psi (2070 bar)
- Flow rates to 450 mL/min at 25,000 psi (1725 bar)
- Guaranteed scaleup to pilot and/or production
- Patented, wear resistant, diamond interaction chamber - no moving parts
- On-board heat exchanger for consistent discharge product temperature
- Ceramic (Zirconia) plunger for extended seal life
- Designed for clean-in-place with no disassembly required
- Available with steam-in-place (SIP) option
- Available explosion-proof option
- CE compliant (Europe)

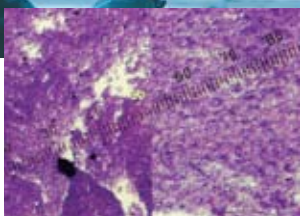

Before processing After processing

Along with other uses the patented Microfluidizer processor produces high-yield cell disruption with easy recovery

Operating Principle

The M-110EH-30 contains an on-board 3.7 kw (5 hp) electric-hydraulic module that powers a single acting intensifier pump. The intensifier pump amplifies the hydraulic pressure to the selected level which, in turn, imparts that pressure to the product stream. Process pressures ranging from 1720 to 2068 bar (2,500 to 30,000 psi) may be selected with the simple turn of a knob.

The intensifier pump is designed to supply the desired pressure at a constant rate to the product stream. As the pump travels through its pressure stroke, it drives the product at constant pressure through the interaction chamber. Within the chamber are specially designed fixed-geometry micro-channels through which the product stream will accelerate to high velocities, creating high shear and impact forces that bring about the desired results as the high velocity product stream impinges on itself and on wear-resistant surfaces.

As the intensifier pump completes its pressure stroke, it reverses direction and draws in a new volume of product. At the end of the intake stroke, it reverses direction and again drives the product at constant pressure, repeating the process.

Upon exiting the interaction chamber, the product flows through an on-board heat exchanger which regulates the product to a desired temperature. At this point the product may be recirculated through the system for further processing or directed externally to the next step in the process.



30 Ossipee Road
 Newton, MA 02464 USA
 Tel: 1-800-370-5452 or: 617-969-5452
 Fax: 617-965-1213
 e-mail: mixinginfo@idexcorp.com
www.microfluidicscorp.com

M-110EH-30 Specifications

Pressure Range	up to 2068 bar (30,000 psi)
Flow Rate	up to 330 mL/min @ 2068 bar (30,000 psi) up to 450 mL/min @ 1725 bar (25,000 psi)
Feed Temperature Max.	75°C (165°F)
Holdup Volume	100 mL
Utility Requirements:	
• Electrical	3 phase 60 Hz service, 208/230/460V, 3.7 KW (5 HP) (50 Hz European standard available)
• Compressed Air	1 SCFM @ 3.4 bar (50 psi) with -18 to 37°C (0 to -35°F) max. dewpoint
• Hydraulic Oil Heat Exchanger Cooling Water	9.5 lpm (2.5 gpm) minimum @ 29°C (85°F) max.
• Product Outlet Heat Exchanger Cooling Water	18.9 lpm (5 gpm) @ 16°C (65°F)
Minimum Sample Size	120 mL
Dimensions	84 x 87 x 148 cm (33"L x 34"W x 58"H)
Weight	205 kg (450 lbs)

M-110EH-30 Standard Features

- Diamond interaction chamber for flow rates up to 330 mL/min @ 2068 bar (30,000 psi) or 450 mL/min @ 1724 bar (25,000 psi)
- Ceramic Auxiliary Processing Module (APM)
- Ceramic (Zirconia) plunger for extended seal life
- Stainless steel enclosure
- Electric-hydraulic power unit
- Gauges for measuring process pressure, hydraulic drive pressure, and hydraulic oil level and temperature
- Self-contained unit, mounted on locking casters for portability
- Minimum sample sizes as small as 120 mL
- Feed temperature range 16°C - 75°C (35°F - 165°F)
- TEFC (totally enclosed fan cooled) motor, starter, controls and power cord

M-110EH-30 Available Options

- 2 liter reservoir
- 2 liter pressure-type reservoir
- Sanitary flush diaphragm pressure transducer with digital readout
- On-board air compressor for air switch activation
- Interaction Chamber cooling bath
- Explosion-proof design
- 2 gallon pressure-type feed tank
- Solvent seal quench system
- ATEX - Zone 1

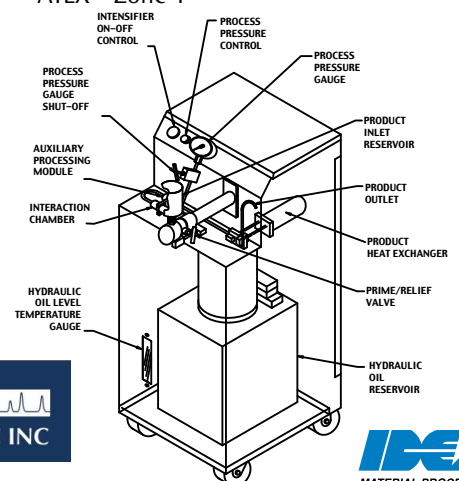

Distributed in Canada by:
 ATS Scientific Inc.
 4030 Mainway
 Burlington ON L7M 4B9
 1-800-661-6700
www.ats-scientific.com

